

Infrared thermography on the spot: Because size does matter

By Leonard A. Phillips

Senior Writer for Infrared Applications, FLIR Systems Infrared Training Center (ITC)

CONTENTS

Summary	1
Understanding the Specifications In the Context of Your Needs	1
How Much Accuracy Do You Want? How Much Do You Need?	3
Questions To Ask	4
Conclusion: Do Your Research — And Try Before You Buy	11
About the Author	11

Infrared (IR) thermography is a fundamental asset in today's predictive maintenance (PdM) and condition monitoring programs. But how can you ensure that the IR camera system you buy today will meet your current and future needs and yield maximum return on investment?

IR thermography is used widely in predictive maintenance and numerous engineering applications. IR cameras enable communications providers and electric utilities to monitor critical components and connections for which unscheduled downtime is unacceptable. They are used by manufacturers to maintain quality and efficiency on production lines. Building managers use them to detect leaks, electrical faults, and moisture concentrations in building materials before they become serious and expensive to repair.

Accurate, reliable and repeatable temperature data provide the basis for a successful thermography program. Thermographers painstakingly collect thermal images and temperature data, organize their findings in an infrared report and typically sign their name to their reports to authenticate the data. These data will serve as the basis for the corrective action decision making process — for delaying repairs, taking equipment off-line for emergency repairs, or other appropriate action. If the temperature data are wrong,

the effectiveness and credibility of the thermographer and the thermography program are destroyed.

There are two tacit requirements for obtaining good data: (1) a camera system with the capabilities needed to successfully perform all required tasks and (2) thermographic training, ideally culminating in operator certification by a reputable training organization.

Understand the Specifications In the Context of Your Needs

When an organization commits to establishing an in-house IR thermography program it is absolutely vital that it purchase a camera system that will meet all requirements and expectations for ALL critical targets and conditions that will be encountered. The right camera can yield a total payback in a single incident. However, making the wrong choice can simply be a waste of time and money.

To make the right purchase decision requires: (1) building a list of all targets and measurement conditions, (2) understanding camera specifications in terms of the tasks that will be required (see Table 1), (3) thoroughly testing the camera on site before making the purchase decision.

Table 1. Basic Camera Performance Specifications and Relevant Questions**Imaging Performance****• Minimum Measurement Spot Size Resolution**

Can the camera fully resolve and accurately measure the temperature of the smallest targets at the working distances and the ambient conditions I will encounter?

• Optics

Does the camera come with a lens that can focus on and enable full resolution of all my targets? If not, can I change lenses to focus on targets at different distance regimes?

• Sensitivity

Can the camera clearly differentiate between the most subtle temperature differences that I will encounter? Can I reduce sensitivity for use with extreme temperature regimes?

• Resolution -- clarity of images produced under all ambient conditions

Can the camera produce images that are sharp and readily interpreted by the eye?

• Video Output/Input

Can I connect the camera to a monitor to see the target enlarged in real-time? Can I connect the camera to a standard video recorder or video camera to capture a measurement procedure? Can I connect a GPS receiver to the camera video input and overlay the thermal data with GPS location data?

• Onboard Video Capability

Can the camera record and playback a full-motion video of objects in motion?

• Onboard Visible Photograph Capability

Can the IR camera also record visible light images of the targets?

Image Presentation**• On-board Display**

Is the display clear and readable? Does the camera have a detachable display screen or support a wearable heads-up-display option for safe and convenient viewing in difficult environments?

• Backlighting Option

Does the display have backlighting for low-light conditions?

Measurement Performance**• Temperature range(s)**

Is the camera able to measure targets at all the temperatures that I will encounter?

• Sensitivity and Accuracy Over the Stated Temperature Range(s)

How accurate are the camera's measurements over the entire range of temperatures? Can it discriminate between all of my targets and their surroundings?

• Measurement Modes

Does the camera offer measurement tools I may need such as movable spot, area maximum, area minimum, area average, and color alarm above or below a value that I can set?

• Set-up Controls

Can I easily set/adjust date/time, °C/°F, language options, scale, information field, on-board display brightness?

• Measurement Corrections

Can I manually set emissivity and reflected apparent temperature?

Special Features and Accessories

• Does the camera have on-board post-processing capabilities? Does the manufacturer offer a range of post-processing software?

• Can I add easy-to-use software for post analysis and report generation?

• Does the camera have a laser target designator?

• Are there accessories that enhance the camera's utility such as a wearable Heads-Up Display (HUD)? A spark shield? A sun shield?

• Is there a 12VDC field recharger that I can use in my vehicle, and a separate battery bay recharger?

• Is there a range of filters?

• Can the camera operate without batteries using a direct 12VDC or 115VAC power source?

• Is a carrying holster available?

How Much Accuracy Do You Want? How Much Do You Need?

Your first step is to create a list of all the targets in your plant or facility that you intend to inspect with the camera. Prioritize each target in terms of its criticality to your operation, the safe or available minimum working distance to each, the ambient conditions, the thermal contrast of all targets and their surroundings, and the frequency with which each target should be inspected. For which targets and under what conditions should complementary inspection methods such as oil analysis, ultrasound, vibration analysis, and motor circuit analysis be used? Be sure to consider additional equipment and processes that may be brought into your plant or facility in the future.

Assuming that the skill of the thermographer is at a high level, temperature measurement accuracy is dependent on the overall performance of the camera system – its optics, focal plane array (FPA) detector, and electronics, and on key target-related factors, which are described in Table 2.

Ultimately, the overall usability and accuracy of the IR camera itself is influenced by three factors:

1. Sensitivity – the camera’s ability to acquire, detect, and measure the target image temperature. A highly sensitive camera will enable surveys to be conducted under less than ideal conditions.

2. Measurement resolution (sometimes called “measurement spot size ratio”) – the camera’s ability to focus the target “spot” on enough pixel elements of its FPA detector to enable the camera to differentiate the target from its background and accurately measure its temperature.

3. Signal processing electronics performance – the ability of the camera’s scanning and processing electronics to interpret and integrate the signal generated by the FPA at which the target spot is processed by the camera’s electronics. Among other factors, the higher the frequency with which the electronics integrate these signals, the better. For example, a 60 Hz scanning frequency will yield a much sharper image that is easier to analyze than a 20 Hz frequency, particularly when the target spot is small and/or it is moving relative to the camera.

Table 2. Key Target-related Factors Affecting Temperature Measurement Accuracy

Working distance to the target – Can the camera accurately measure the target at the working distances you will encounter? Is there a high-temperature, high-voltage, or other condition that keeps the operator at a relatively great distance? For example, is the target very small and also at a great distance, such as a line splice on a transmission pole? Or do you need to cover large areas quickly, as in roofing inspections? Does the camera system accept lenses with different fields of view to accommodate these and other telescopic and wide-angle imaging requirements?

Target emissivity (the relative efficiency with which the target gives off IR radiation on an increasing scale from 0 to 1. The higher the target’s emissivity, the closer to its true temperature it appears to the IR camera) – Can the camera be adjusted to compensate for different target emissivities?

Thermal differential between the target and the background – Is the camera sensitive enough to distinguish the target from its surroundings?

Reflected apparent temperature (the uncompensated reading from an IR camera containing all radiation incident on the camera that is reflected from the target, regardless of its source) – Compensating for reflected radiation is a challenge best met by operator experience and a thorough understanding of the IR characteristics of the target and its surroundings.

Questions To Ask

The following questions and answers can help guide an organization toward an optimal IR camera purchase decision:

Q: How much sensitivity do you need?

A: The sensitivity of an IR camera is sometimes expressed as Noise Equivalent Temperature Differential (NETD), which is the smallest temperature differential that the camera can detect under stated conditions. But NETD is determined under laboratory conditions, and actual camera performance should be assessed in the context of your application needs. In other words, there's nothing better than a demonstration of camera capabilities in your facility, with the full range of targets and environmental conditions that will be encountered on the job.

For example, in roofing or building envelope moisture surveys, which are composed primarily of near-ambient temperature targets, very high sensitivity on the order of less than ± 1 Fahrenheit degree may be required to enable the thermographer to discern between dry materials and very slightly warmer or cooler wet areas that must be replaced or repaired. In this case, a camera with a stated NETD of 0.1 Celsius degree or smaller is a much better choice than one with an NETD of, say, 0.25 Celsius degree or greater.

However, to measure high-temperature targets such as kilns or refractories, high sensitivity cameras actually need to be made less sensitive using filters, apertures, or decreased variable integration time on the detector. Without this attenuation, the sensitive detector would be saturated with signal in the same way your eyes are blinded by the sun. If your camera must be used in both low and high temperature regimes, be sure it can compensate for all conditions you're likely to encounter.

Q: How much resolution do you need?

A: Measurement resolution is extremely critical to accuracy and can be described as the smallest target spot size that can be reliably and accurately measured by the camera. The further the operator moves away from the target, the smaller the target appears and the harder it is to accurately measure its temperature.

If you need to accurately measure the temperature of, say, a 1-inch spot from a 20 foot working distance, you will need a camera that can achieve resolution in this regime. Conversely, if you need to inspect a target that is small and very close to the camera, say, a bolt or a section of 14 or 16 gauge wire inside a motor control center that is only 12 inches away, your camera will have to be able to focus and resolve at this working distance as well.

Resolution can be described as the ability of the camera to accurately measure the temperature of a certain diameter target "spot" at a maximum distance. The ratio of the maximum distance at which a camera can accurately resolve and measure a minimum spot size to the spot size itself is called the camera's maximum "distance to spot size ratio" or simply "spot size ratio."

For example, consider a camera that can accurately measure a target spot of 1 inch at a working distance of 120 inches. The distance to spot size ratio of that camera system is 120:1. Can the camera measure your 1-inch target at a distance of 20 feet? To find out, calculate the minimum spot size the camera can measure at this working distance.

First, consider:

Spot size ratio = 120:1 = the ratio of the maximum distance to the smallest target spot that is measurable at that distance.

Call the unknown minimum spot size "**X**" and convert all dimensions to inches:

$$120:1 = (20 \times 12):X = 240:X$$

Solving for X:

$$120:1 = 240:X$$

$$120X = 240$$

$$X = 2 \text{ inches}$$

This camera as described cannot measure a spot that is smaller than 2 inches across at this distance. The simple answer to the question is "no." However, cameras that have interchangeable lenses enable you to change the spot size ratio by changing the camera optics. Here's why.

The high-performance FPAs in today's industry standard IR cameras are built by state-of-the-art photolithography, micro machining and silicon processing techniques into a matrix of individual "unit cells," or pixel elements, that "stare" at the image projected onto them through the camera optics. Each of these pixel elements individually reacts to the relative strength of the

IR radiation that falls on its active surface by varying the electrical signal it sends to the camera electronics. An FPA may contain thousands of such elements. The electronics digitize and integrate all of the individual signals from all of the pixel elements, ultimately producing a composite thermographic image (see Figure 1).

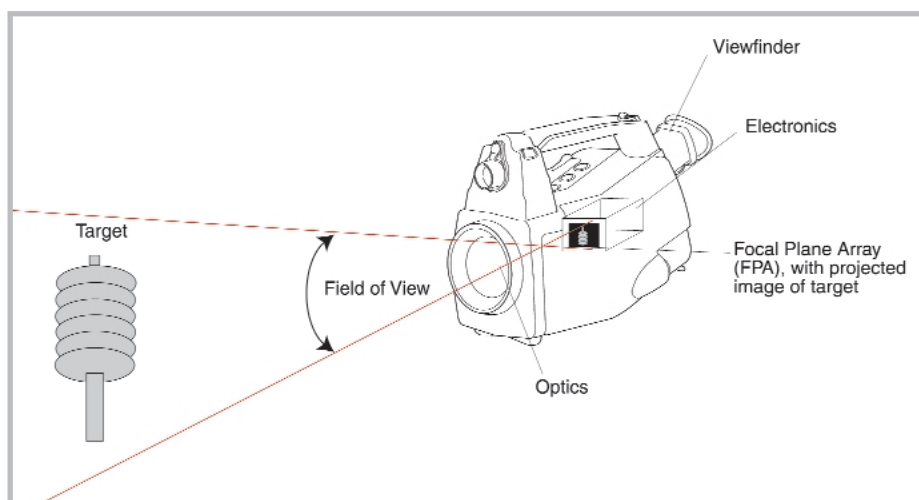

Figure 1: Overview of IR camera components. The lens focuses the target image on the photosensitive pixel elements of the FPA, which react by changing the electrical signal they send to the electronics. A 320 x 240 element FPA has 76,800 such elements. The electronics of high-performance cameras can scan each element 60 times a second, or 60 Hz, integrate the signals to produce a thermographic image, and save the data in memory.

However, there is a limit to accuracy. With today's FPA detectors, the image must fall on a minimum cluster of at least 3 x 3 pixels to enable the electronics to achieve acceptable measurement accuracy. It is the job of camera optics to focus the image on at least this number of pixels. If the image of the target falls on fewer than a 9-pixel cluster, the camera will produce a temperature reading that is a combination of the temperature of the target spot itself and the area surrounding the target that is also imaged on the 3 x 3 pixel cluster (see Figure 2).

A telescopic (sometimes called "telephoto") lens will provide greater magnification of the image on the FPA than a wide angle lens, but it cannot focus on nearby objects. In practical terms, a telescopic lens is required to measure small targets at great distances, and a wider angle lens is needed when you must focus on nearby objects or survey large areas quickly (see Figure 3).

Conclusion: Be sure to select a camera system that includes a range of interchangeable wide angle, normal, and telescopic lenses that will accommodate all of the spot size to distance ratios you will encounter.

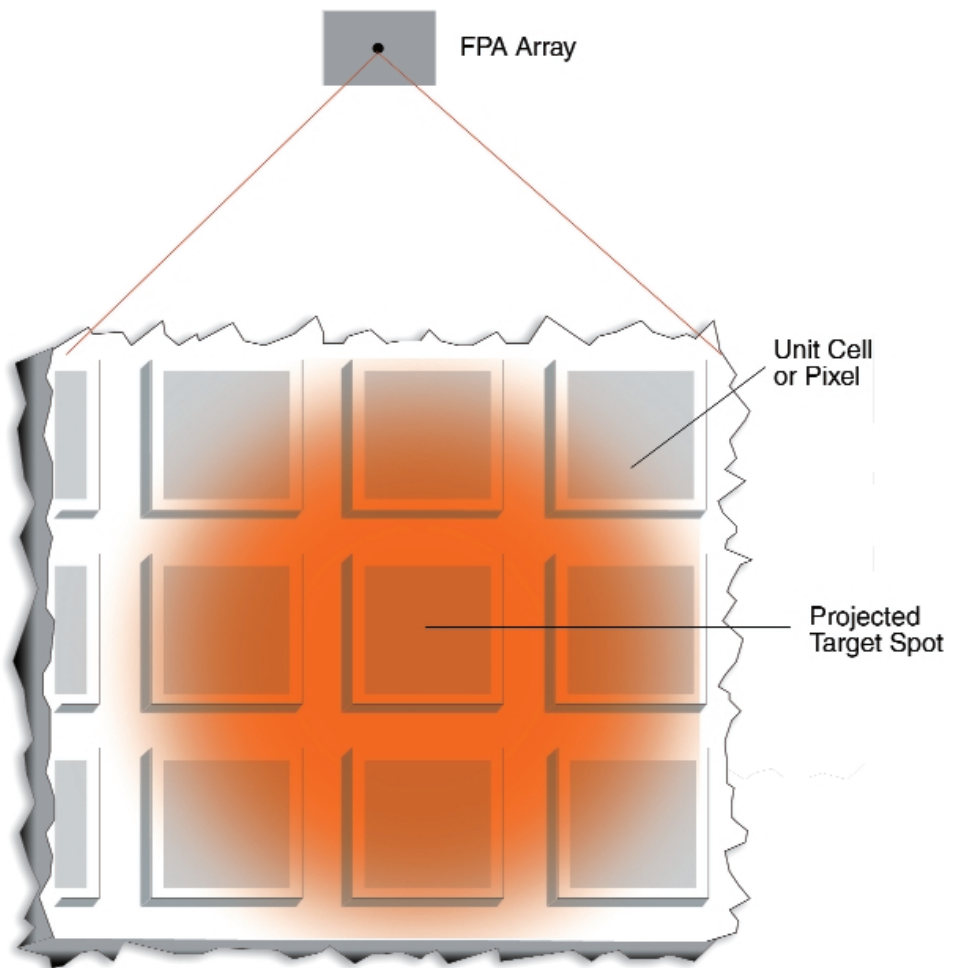

Figure 2: The image of the target spot must fall on a minimum cluster of at least 3 x 3 pixels of the FPA to achieve acceptable measurement accuracy.



Description of Lens	Minimum Working Distance of Lens	Images Taken of a Disconnect from the Same Position and Camera, and With the Lenses Indicated
<p><i>NOTE: All lenses can focus targets from the minimum working distance to infinity.</i></p> <p>7° Field of view – extreme telescopic</p>	6 meters (19.69 ft)	<p>7 Degree Lens</p> 
12° – telescopic	2 meters (6.56 ft)	<p>12 Degree Lens</p> 
24° – “standard”	0.5 meters (1.64 ft)	<p>24 Degree Lens</p> 
45° – wide angle	0.2 meters (0.66 ft)	<p>46 Degree Lens</p> 
80° – very wide angle	0.2 meters (0.66 ft)	<p>80 Degree Lens</p> 

Figure 3: Be sure to choose a camera system that can focus and resolve targets at your actual working distances. Compare the minimum working distances and the relative magnification of the target taken by the different lenses. To accommodate small nearby objects as well as similar objects at much greater distances, you will need a camera system that includes interchangeable lenses.

Q: Can the camera focus at all working distances encountered?

A: In practical terms, if the camera is used in an electric power utility environment, it must routinely and accurately resolve targets about one-inch across in a substation or on a pole-mounted transformer or insulator from a typical distance of, say, 20 feet or more under a wide range of ambient conditions.

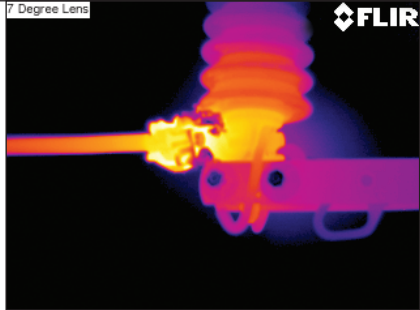
In this case, accurate measurement requires a camera with a 240:1 spot size ratio, which will require a telescopic lens. Similarly, examining small and distant targets such as bearings on overhead conveyor systems, insulators in outdoor substations, hot spots on steam traps and on overhead buses requires the use of a long-focus telescopic lens to project the target image on at least a 3 X 3 pixel area on the FPA (see Figure 2).

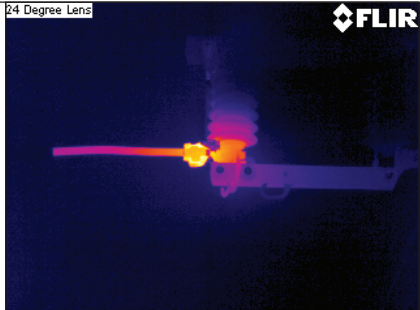
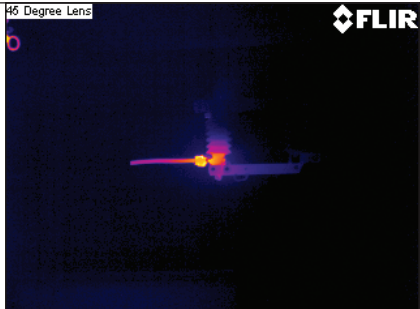
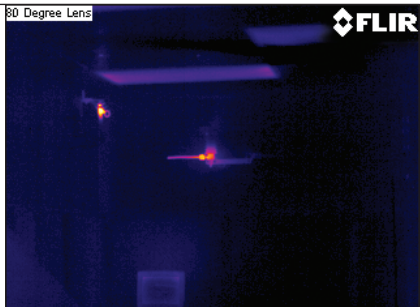
However, if the same camera must be used to inspect an electrical connection or a section of 16 gauge wire in close quarters that require the camera to be only 18 inches away, a very different lens will be required to accommodate the short working distance as well as the small target spot size.

Conclusion: As before, select a camera system that includes interchangeable lenses that will accommodate all of the working distances and spot size to distance ratios you will encounter.

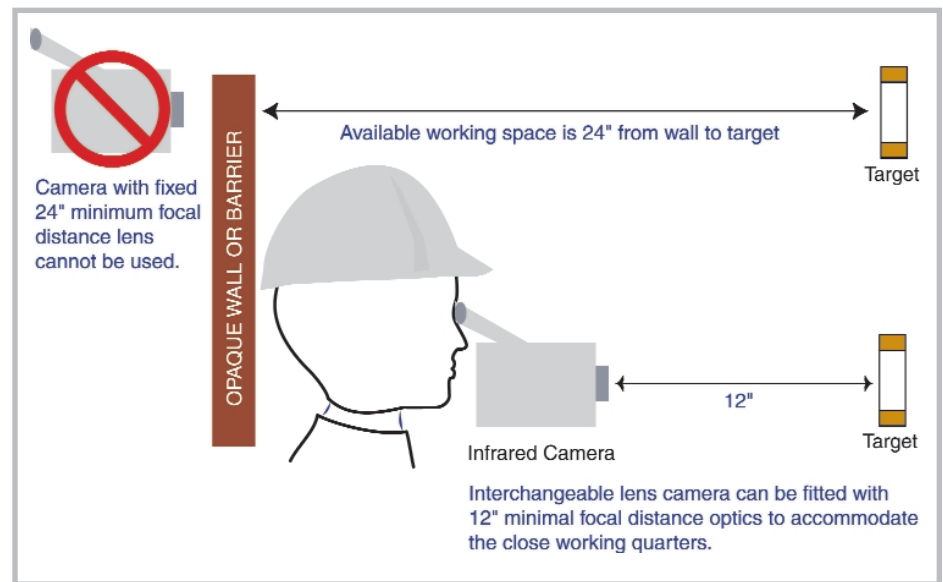

Figure 4: In a close working quarters situation, minimum focal distance can be critical. The camera at the top of the figure can't be used because it has a fixed lens that can focus targets that are no closer than 24 inches away. The camera below is fitted with a lens that can focus on targets as close as 12 inches away, and it also accepts other lenses with different focal lengths.

Q: What is scan speed and how does it affect accuracy?

A: The speed with which the camera electronics “scan” the FPA pixel element signals is analogous to the shutter speed on an ordinary visible light video camera. The faster the scan speed, the sharper will be the image of targets that are moving relative to the camera and the more accurate will be the temperature measurement. Conversely, the slower the scan speed, the more “smear” will appear in the image and the less accurate will be the measurement.

For example, moving overhead conveyor systems, belt drive motors, resistance weld robots and dozens of other industrial targets need to be imaged in real time in order to make a judgment on their condition. Utility thermographers may need to scan overhead distribution lines with their IR camera while moving in vehicles. A camera with a scan speed of 60Hz will produce far superior images than one with a scan speed of only, say, 20 Hz. In fact, image smear and distortion that results from a 20 Hz scan speed may make such cameras unsuitable for applications where motion is present.

Q: Will the camera be used in constant or variable ambient temperature environments?

A: In the real world, a thermographer will have to work in a wide range of ambient conditions. You must be confident of the camera’s accuracy over the entire temperature range of targets and conditions you will encounter, especially if readings are to be archived and used to trend temperature variations on equipment in variable temperature environments over time. Insist on a specification of accuracy that is maintained over the entire temperature range that will accommodate your targets, such as: “ $\pm 2\%$ or $\pm 2^\circ\text{C}$ ” without restrictions stated.

Beware a camera with a specification of thermal measurement accuracy that is pegged to one ambient temperature, such as: “ $\pm 2\%$ or $\pm 2^\circ\text{C}$, whichever is greater, at calibration geometry and 25°C ”. There’s simply no way to tell how accurate such a device will be in higher or lower temperatures than 25°C !

Q. What about other camera features?

A: Some thermographic situations will require special features that may or may not be included in the specifications. Be sure you understand what the camera system offers. Some examples:

Video output. Do you want to connect your camera to a video recording device to document thermal events such as electrical distribution line scanning, rotating belt problems, steam trap cycling, overhead steam line analysis and other applications that can only be presented properly through live video imaging? If so, be sure it has a standard RCA video output connector and that the output supports video industry standards. A USB output port can only be used to download static images.

Report generating software. Thermographers must generate reports that present their findings in a clear, professional format. Be sure the camera system you purchase supports easy-to-use post analysis software and report generating applications that meet your requirements and are compatible with your computer system.

Rechargeable batteries. It's no accident that lithium ion batteries are the standard for cell phones, power tools, and PDAs. Li-ion technology provides the ultimate optimization of power, size and weight, and the convenience of 12VDC and 115VAC recharging.

While nonrechargeable alkaline and "ultra" alkaline cells may appear to be an attractive option at first glance, they are unsuitable for high current-drain devices like infrared cameras because of their inability to supply large currents and rapid voltage drop. They add two times the size and weight to deliver the same power capacity of a standard lithium ion (Li-ion) rechargeable battery. Alkaline batteries also can leak and create havoc inside your camera, and must be disposed of safely.

Unlike alkaline batteries, Li-ion rechargeable batteries can maintain a steady voltage throughout their discharge cycle — enabling hundreds, rather than merely a handful of thermograms to be taken. And then of course you can recharge them up to a thousand times!

Weight. If portability is an issue for you, don't assume that you must sacrifice camera performance for weight. While the size of the array does matter, so do all the other camera components. State-of-the-art cameras based on current industry standard 320 X 240 pixel arrays can produce stunningly sharp images. But today's leading high-performance 160 x 120 pixel cameras also provide far superior imaging performance than older and much heavier cooled array products, yet weigh only 1.5 pounds with batteries — about the heft of a household flashlight! If you opt for a highly portable 160 x 120 camera system, be sure at minimum that it accepts interchangeable lenses for maximum flexibility in the field and offers a scan speed of 60 Hz to support real-time video output to a monitor or video recorder.

FLIR ThermoCAM® E4. Light and powerful, weighing only 1.5 pounds with rechargeable Li-ion batteries. Interchangeable optics. Has 160 x 120 FPA.



FLIR ThermoCAM P60. Extremely high resolution, yet weighs only 4.4 pounds with batteries, convenient detachable viewscreen. Interchangeable optics. Has 320 x 240 FPA.



FLIR IR Heads-Up-Display (wearable optics) presents the camera's imaging directly to the eye, enhancing safety and productivity.



Conclusion:
Do Your Research —
And Try Before You Buy

Choosing the right infrared camera requires understanding the full range of your target variables—their size, distance, and infrared characteristics, and environmental factors. It also requires understanding your requirements in terms of camera sensitivity, resolution, and overall accuracy.

The best advice you can follow is to try before you buy! Camera specs are generated under laboratory conditions. To confirm that a camera system performance meets your needs, insist on a demonstration at your facility and on typical targets, and ideally in the hands of your own thermographer.

Remember, purchasing the right camera can yield a total payback in a single incident. However, purchasing on price alone can simply be a waste of time and money. “There is nothing in the world that some man cannot make a little worse and sell a little cheaper, and he who considers price only is that man's lawful prey.” —
John Ruskin (1819–1900)

About the author

Leonard A. Phillips is senior writer for infrared applications at the Infrared Training Center (ITC) in North Billerica, MA. ITC is the global leader for infrared thermography training.



The Global Leader in Infrared Cameras

FLIR Systems, Boston
Americas Thermography Center
16 Esquire Rd.
North Billerica, MA 01862

1-800-464-6372
www.flirthermography.com